



Digital Power Amplifier: DUO AMP User's Manual

TABLE OF CONTENT

1. INTRODUCTION	2
2. FEATURES	2
3. CONTROL ELEMENTS	3 + 4
3.1 Front Panel	
3.2 Rear Panel	
4. CONNECTION OF THE DUO AMP	5
5. TECHNICAL SPECIFICATIONS	6
6. WARRANTY.....	7
7. WARRANTY REGISTRATION.....	8

Preface

Dear Customer,

Thank you for choosing the DUO AMP and thank you for choosing a product resulting from WLM's research. For our WLM TEAM, music and sound are more than a job. They are first and foremost a passion – even an obsession!

The DUO AMP with the Active Crossover is the result of many hours of listening and tests.

1. INTRODUCTION

The WLM DUO AMP is a class D digital power amplifier with advanced features and great efficiency, custom-built for our WLM DUO subwoofers. It delivers tremendous power in a small package, providing high-level performance under even the most demanding conditions. The amplifier contains two independent channels with separate AC transformer, power supplies and protection system. Each channel has independent protective circuitry against open circuit, short circuit, mismatched loads and over temperature.

2. FEATURES

- 1.5U height and 1/2 rack space, stereo high power amplifier
- Built in WLM active crossover
- Adjustable bass equalizer
- Input select for high and low level signal
- Fantastic audio quality even with extremely high output levels
- Solid and durable, can be mounted into a cabinet
- User-controllable limiter
- 2x 480 Watts into 4 ohms (EIAJ)
- 2x 260 Watts into 8 ohms (EIAJ)
- 2x 245 Watts into 4 ohms (RMS)
- 2 COMBO input connectors are compatible with balanced XLR and JACK
- NEUTRIK Speak-on connectors for outputs
- Front panel LED indicators for clip, limit, power on and signal
- Accurate level control

3. CONTROL ELEMENTS

3.1 Front Panel:

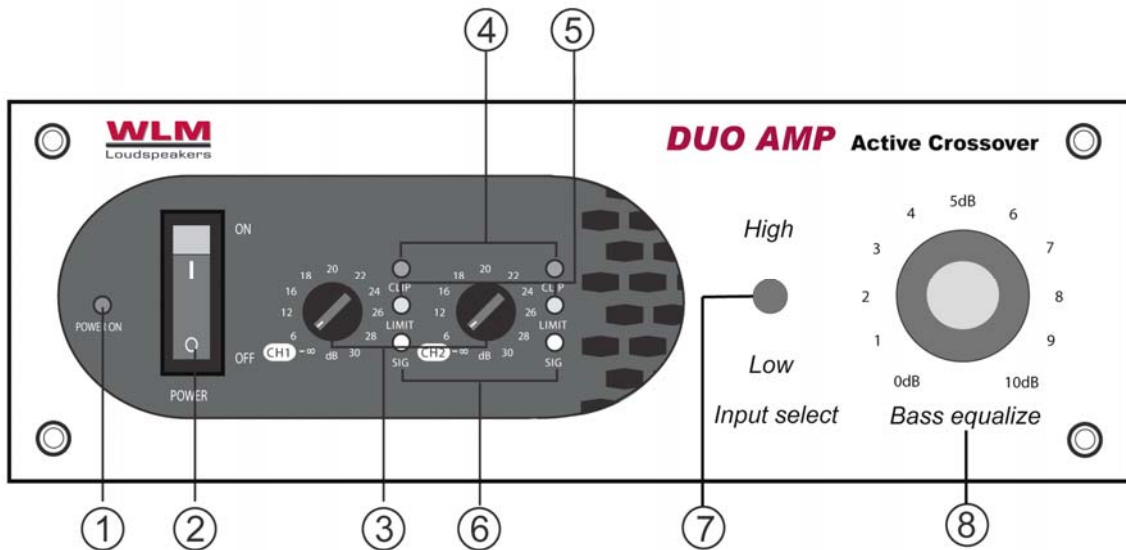

- (1) **Power LED**
This LED lights up when the unit is powered on.
- (2) **Power Switch**
Turns the unit on or off.
- (3) **Level Control for Channels 1 & 2**
Adjust the output signal level for each respective channel.
- (4) **Clip LED**
When this LED lights up, the output level is too high and it is time to reduce the signal level until the clip LED turns off.
- (5) **Limit LED**
While the unit is limiting the output signal, this LED lights up.
- (6) **Signal LED**
When the unit senses incoming signal, this LED lights up.
- (7) **Input select**
High-level position: Signal from speaker outputs of an integrated or power amp
Low-level position: Signal from main output of a preamplifier or processor
- (8) **Bass equalizer**
Adjusts bass compensation

3.2 Rear Panel:

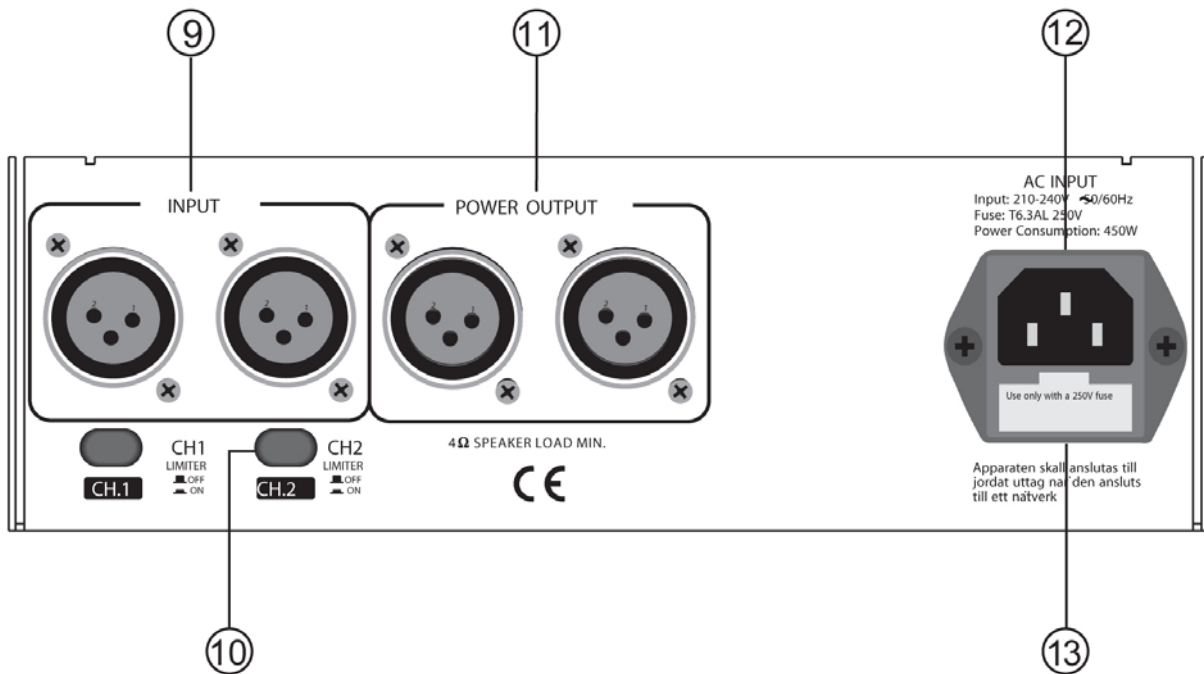

(9) Input Connector

These connectors connect the input signal of channel1 and channel 2 separately.

(10) Limiter Switch

With this switch of CHI or CH2 in the "ON" position, the limiter activates for the respective channel to protect the apparatus once the output level exceeds the maximum permissible output level. In the "OFF" position, the limiter doesn't work.

(11) Output Connector

These NEUTRIK Speak-on connectors are used to connect to your speakers.

(12) AC Input

Use it to connect your DUO AMP with the supplied AC cord only. Please check the wall voltage in your country before attempting to connect the unit to the main AC.

(13) Fuse Holder

The fuse protects the AC supply circuit of the equipment.

CAUTION: if the fuse needs replacing, only use the recommended fuse type as indicated on this unit. If the fuse continues to blow after replacement, discontinue use of this unit until it has been repaired.

4. CONNECTION OF THE DUO AMP

LOW Level Connection

(switch on the front in LOW Level position)

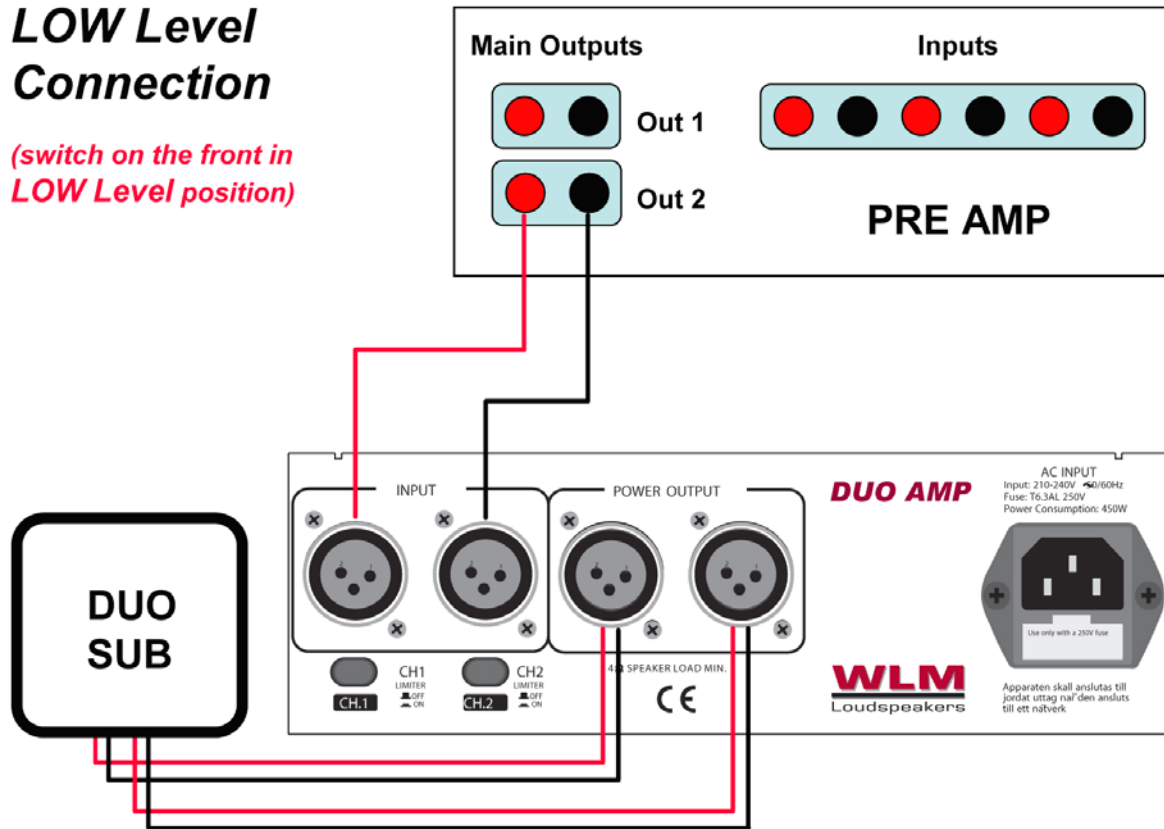

HIGH Level Connection

(switch on the front in High Level position)

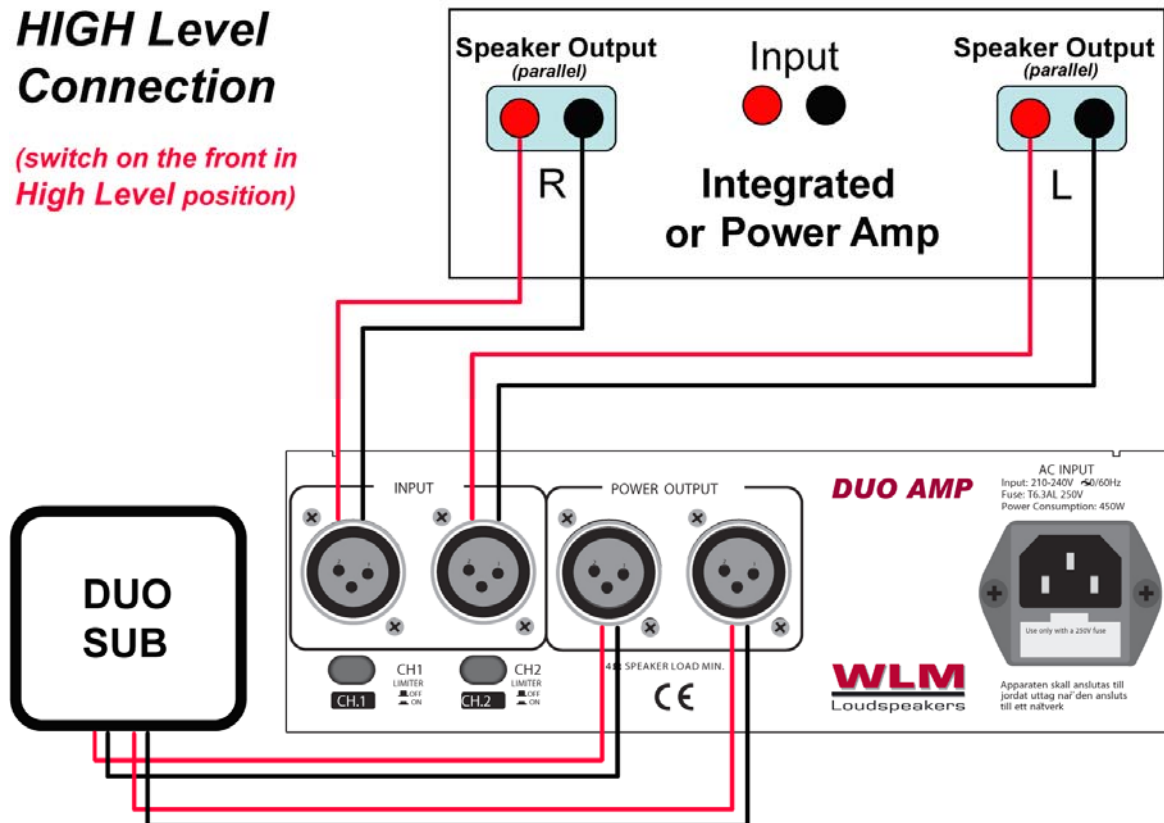

5. TECHNICAL SPECIFICATIONS

MODEL	WLM DUO AMP
20Hz 20kHz@0.1%THD, Stereo Mode	
8 ohms per channel(EIAJ)	260W
4 ohms per channel(EIAJ)	480W
Input Sensitivity @4 ohms	+3dBu
Controls	FRONT: Power switch, CH1 & CH2 LEVEL knobs, Input select switch, Bass equalizer knob
	REAR: CH1 & CH2 LIMITER
Indicators (per channel)	Power-On: Green LED
	Clip: Red LED
	Limit: Yellow LED
	Signal: Green LED
Connectors of each channel	Input: COMBO connector
	Output: NEUTRIK Speak-on connector
Power Supply	190-240 Vac ~50Hz / 95-120Vac ~60Hz
Dimension	314W x 208.5D x 66.6H mm / 12.4" x 8.2" x 2.6"
Net Weight	3.85 kg (8.49lb)

6. WARRANTY

Limited Warranty

During the warranty period the WLM company guarantees this product to be functioning properly and without flaws.

The warranty period for the WLM DUO AMP is 2 years (counted from the date of purchase from an authorized WLM dealer).

Condition for warranty service is that the product be operated in accordance with this manual.

During the warranty period, WLM will replace or repair defects free of charge to the customer.

To benefit from this protection, the following conditions must be observed:

- The warranty registration card is received by WLM within 30 days after the date of purchase.
- The enclosure shows no signs of tampering and the insides show no signs of overheating due to wrongful installation/operation resulting in overloading and burning out certain parts.
- The PCBs and components thereof are not showing signs of tampering, regardless of whether the intention was to repair or modify the unit.
- There is no indication whatsoever that the WLM product was operated differently than specified in this manual.

In addition, the customer will lose the right for a warranty claim if the serial number of the unit in question has been modified, removed or tampered with. WLM will not be held responsible for damages resulting from repairs executed by unauthorized personnel.

Collateral Damage

During the duration of this limited warranty period (and thereafter), WLM will not be responsible for collateral damage linked directly or indirectly to the operation of the WLM product.

Warranty Claim

The customer may on the basis of this limited warranty claim the repair or replacement of the defective part by the manufacturer or the authorized dealer with no charge. For the claim, please contact either WLM directly or the WLM distributor in your country. After receipt of the claim confirmation, please send the unit under claim to the address shown below or presented to you by your distributor. The defect will be examined and, when justified, repaired at no cost. The customer will have to bear the cost of shipment. Without a corresponding warranty activation (received within 30 days after the date of purchase at the address below), no warranty claim will be accepted or processed.

WLM Loudspeakers
Trietstrasse 56
6832 Sulz / AUSTRIA

Phone: +43 (0)5522 44641 (Customer Service)

e-Mail: info@wlm-loudspeakers.com

Web: www.wlm-loudspeakers.com

WLM Warranty Registration

Please ask your dealer to fill in this form at the time of the purchase.

This registration will entitle you to call on WLM for technical support and it is a prerequisite for an eventual warranty claim against WLM.

Please send your registration to:

WLM Loudspeakers
Treietstrasse 56
A-6832 Sulz
Austria

Customer Service:

Phone : +43 (0)5522 44641

Fax : +43 (0)5522 44641-74

Web : www.wlm-loudspeakers.com

Unit/Model: **DUO AMP**.....Serial-Nr.:.....

Date of Purchase:.....Dealer Name:.....

Dealer Address:.....

First/last name of customer:

Address Street:

Postal Code/Town:

Customer Contact Phone:

Fax:

E-Mail:

Your comments are always appreciated: