

FEATURES

- **Core**
ARM® Cortex®-M3 ATSAM3U
CPLD XILINX® XC2C64A
- **OSCILLATORS**
TCXO 24.5760 Mhz Low phase noise
TCXO 22.5792 Mhz Low phase noise
- **USB**
USB 2.0 High Speed dedicated 12Mhz crystal
Class 2 compatible
No drivers for Mac OSX® 10.6+
No drivers for Linux with UAC2 Kernel compliant
WDM Kernel Streaming/WasaPI/DS MS Windows® XP/Vista/Win7
32bit/64Bit tested with Win 8 preview.
- **AUDIO**

PCM over USB sample rates 44.1Khz 48Khz, 88,2Khz,96Khz,192Khz
352.8Khz, 384Khz I2S output

DSD over USB freq. 2.822 Mhz, 3.072 Mhz, 5.644 Mhz, 6.144 Mhz. PCM token FA05
- **OUTPUT**
LVC MOS33
- **Powered by USB 5V bus. Power Consumption is 605 mW at max speed.**
The module mounts an ultra low noise LDO ADP-151-3.3V
- **ROHS and CE certified**



DESCRIPTION

The combo384 is an USB audio device adapter for OEM applications. USB PCM audio data (2 Channels) accepted in input are converted in an I2S stream or DSD native stream. The PCM sample rates supported are 44.1 Khz, 48 Khz, 88,2 Khz, 96 Khz, 176,4 Khz, 192 Khz, 352,8 Khz, 384 Khz.

The DSD over USB format is detected when PCM sample with an alternate sequence of 32 FA05 token in the MSB part is received. The DSD managed frequencies are 2.822 Mhz, 3.072 Mhz, 5.644 Mhz, 6.144 Mhz. With ASIO Driver <http://www.amanero.com/asio> it's possible to play native DSD extending the range to DSD256 and DSD512.

An incoming DSD stream is indicated by an asserted signal in a specific DSD ON pin of the output comb connector and the I2S DATA and I2S FSCLK pins become the DSD Left/Right output pins.

The module works in Master Mode Only, it means that it doesn't accept an external clock in input.

Output connector

header 10x2 row 2.54 pitch

1	Cable Plugged	-	It's "1" When the usb cable is plugged
2	Reserved	-	
3	I2S DATA/DSD1	Out	Data stream LVCMOS 3.3V 47ohm
4	I2S CLK/DSD CLK	Out	Clock LVCMOS 3.3V 47ohm
5	I2S FSCLK/DSD2	Out	Frame sync LVCMOS 3.3V 47ohm
6	MCLK	Out	Actual Master Clock 24.576Mhz or 22.5792Mhz
7	DSD ON	Out	This line is "1" when a DSD stream is detected. (FA05 in the PCM envelope MSB) LVCMOS 3.3V
8	GND	Power	Ground Terminal
9	3.3V output (max 50mA)	Power	This output can be used to power an isolator or it can be used to detect when the usb is connected to the PC.
10		Out	
11	MUTE	Out	This line is "1" during a sample rate change or when the DSD mode is changing.
12	Reserved	-	
13	GND	Power	Ground Terminal
14	GND	Power	Ground Terminal
15	GND	Power	Ground Terminal
16	GND	Power	Ground Terminal
17	GND	Power	Ground Terminal
18	GND	Power	Ground Terminal
19	GND	Power	Ground Terminal
20	GND	Power	Ground Terminal

Output Connector pinout

[11] Mute	[12] SDA	[13] GND	[14] GND	[15] GND	[16] GND	[17] GND	[18] GND	[19] GND	[20] GND
[1] Plug	[2] SCL	[3] DATA	[4] CLK	[5] FSCLK	[6] MCLK	[7] DSDon	[8] GND	[9] 3.3V	[10] 3.3V

Windows Drivers can be downloaded at <http://www.amanero.com/drivers.htm>

ELECTRICAL CHARACTERISTICS

ABSOLUTE RATINGS*

Storage Temperature.....-40°C to + 85°C

Maximum Operating Voltage5.5V USB supply

***NOTICE: Stresses beyond those listed under "Absolute Maximum**

Ratings" may cause permanent damage to the device.

This is a stress rating only and functional operation of the device at these or other conditions beyond those indicated in the operational sections of this specification is

not implied. **Exposure to absolute maximum rating conditions for extended periods may affect device reliability**

For more info please read <http://www.amanero.com/drivers/combo384-D.pdf>

DC Characteristics

VCCIO 3.3V

Symbol	Parameter	Min	Max
VOH	High level output voltage	$V_{CCIO} - 0.4V$ ($I_{oh}=-8mA$)	-
VOL	Low level output voltage	-	0.4 V ($I_{ol}=8mA$)
Pdc	Power consumption at 32/384Khz		605mW

Timing Diagrams

I2S Mode

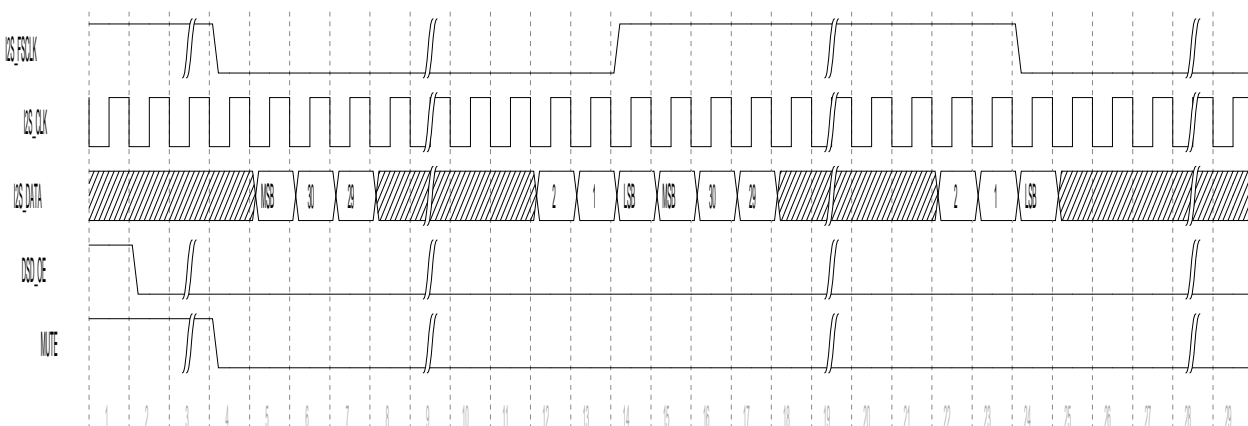

DSD Mode

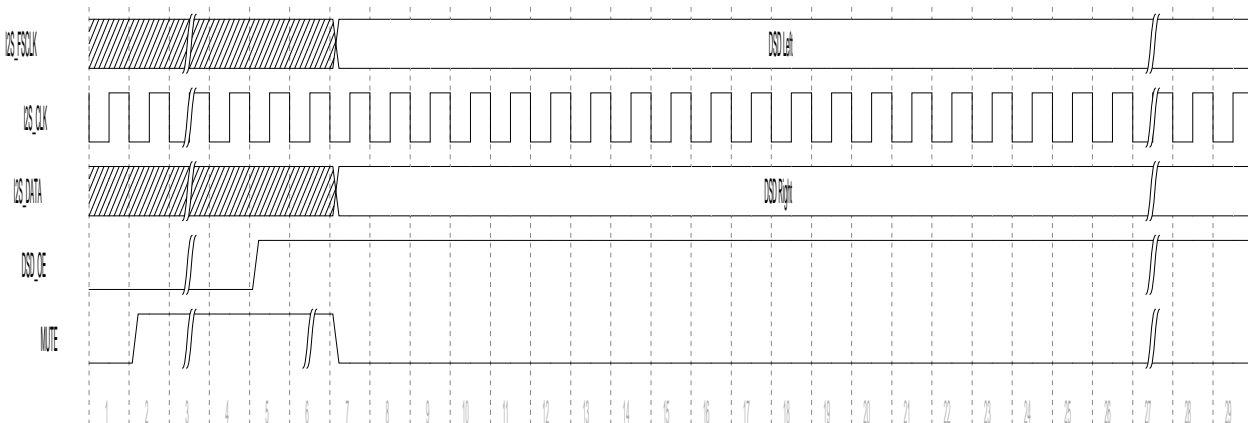

In DSD Mode the I2S_CLK becomes the DSD clock signal, the I2S_FSCLK becomes the output

data line DSD1 and I2S_Data becomes the DSD2 Line.

Application Note

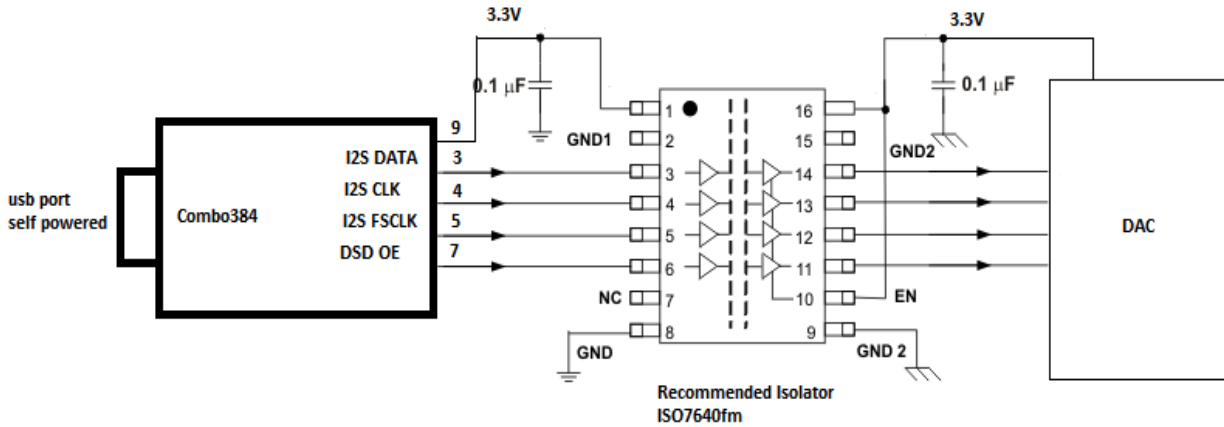

Fig.1 - Isolator between the module and the DAC.

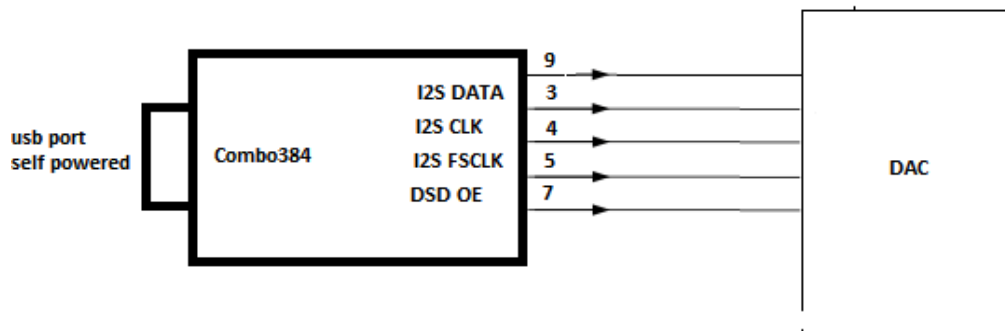
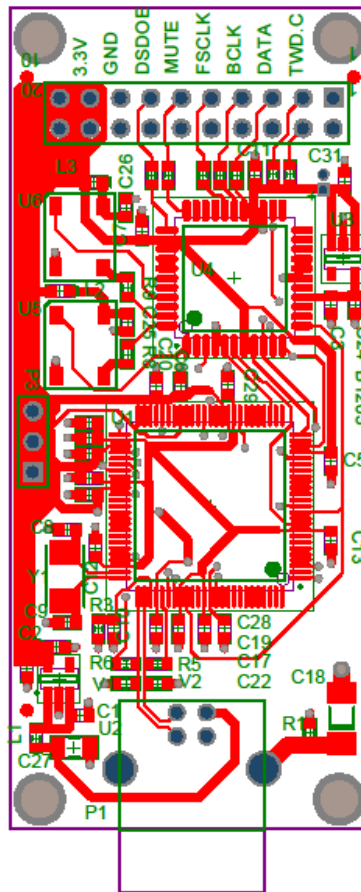
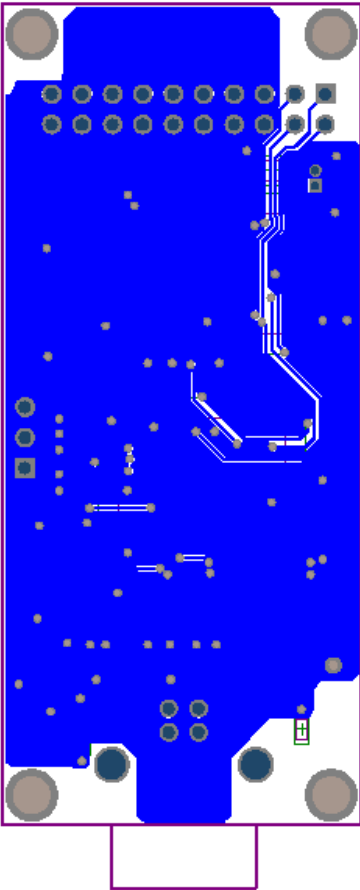

Fig. 2 - Without isolator.
The pin 9 3.3V can be used to detect when the usb is plugged and the module powered.

GERBER TOP



GERBER BOTTOM



MECHANICAL CHARACTERISTIC

distances are in mm

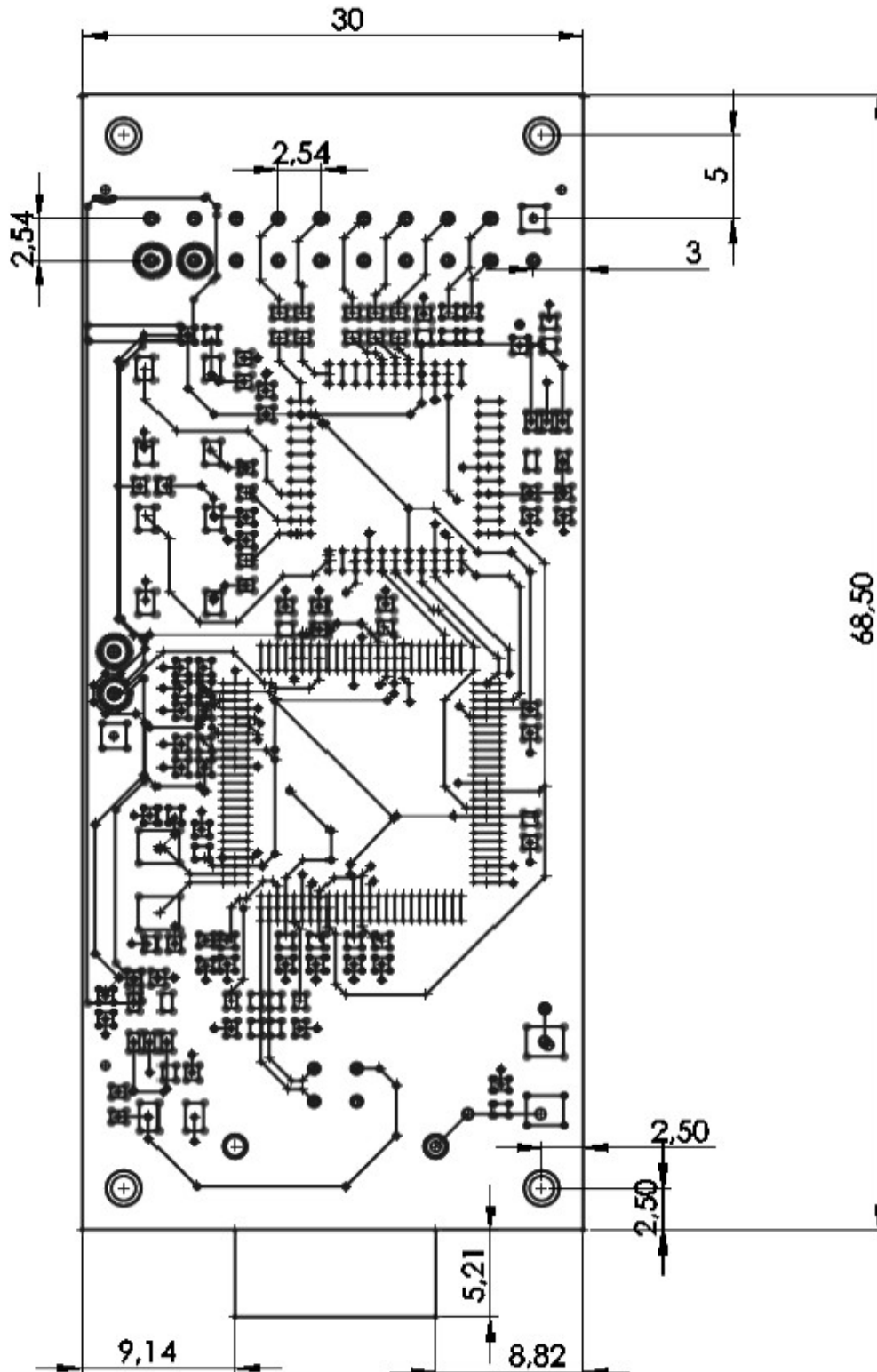



COMBO384 USB TO I2S DSD CONVERTER

Preliminary Datasheet
version 26/01/2012 Rev D
Amanero SRL All rights reserved

NOTICE

This product is ROHS and CE certified.

Amanero SRL reserves the right to make corrections, modifications, enhancements, improvements, and other changes to its products and services at any time and to discontinue any product or service without notice. Customers should obtain the latest relevant information before placing orders and should verify that such information is current and complete. This is a preliminary datasheet and is not complete.